



WD26

User Manual

Walk-Behind Scrubber
Traction Drive Disc Deck

www.bulldogscrubbers.com
877-292-3935

This manual is furnished with each new **Bulldog WD26**. This provides the necessary operating and preventive maintenance instructions. Operators must read and understand this manual before operating or servicing this machine.

This machine was designed to give you excellent performance and efficiency. For best results and minimal cost, please follow the general guidelines below:

- Operate the machine with reasonable care.
- Follow the manufacturer's suggested maintenance instructions as provided in this booklet.
- Use original Manufacturer supplied parts.

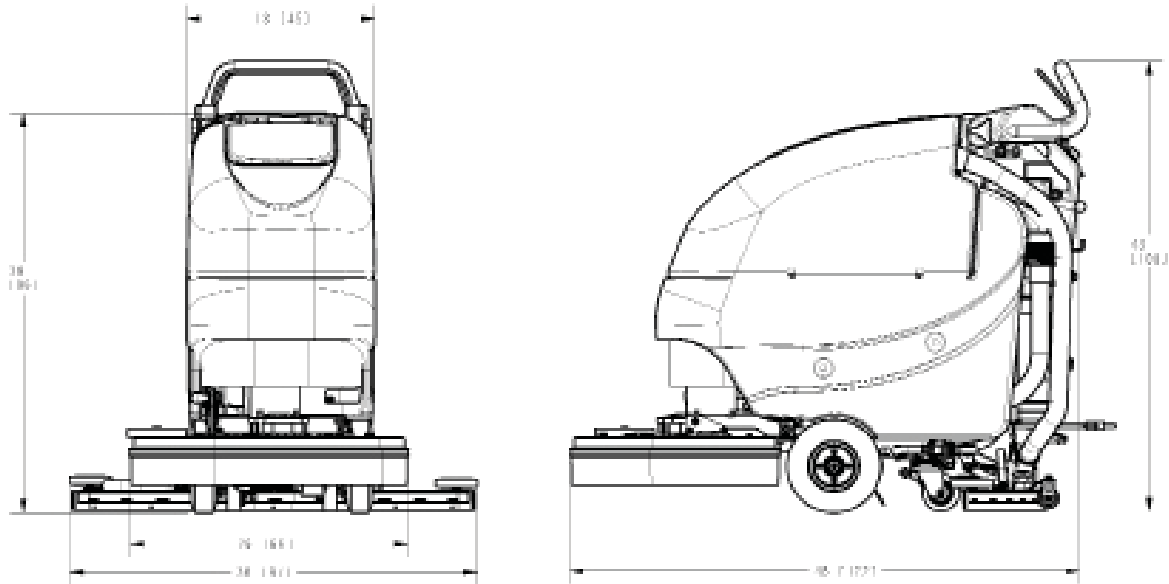

Technical Specifications

Model *Bulldog WD26*

Model No. WD26

Current (Max)	40 amps
Battery Capacity (Lead Acid)	140Ah @ 20 hr
Battery Capacity (Gel)	95Ah @ 20 hr
Sound Level	69 dBA
Cleaning path width	26 in (65 cm)
Squeegee width	38 in (95 cm)
Productivity	30,500 ft ² /hr (2830 m ² /hr)
Working Speed	2.7 mph (4.3 km per hr)
Transport Speed	2.7 mph (4.3 km per hr)
Rated voltage	24 volts
Vacuum flow	65 cfm (110 m ³ /hr)
Vacuum waterlift	45 inches (112mbar)
Vacuum power	.60 HP (450 W)
Brush type	Disc
Brush motor(s) power	3/4 HP (550W)
Number of brushes	2
Brush RPM	180 RPM
Solution capacity	12 Gal (45 liters)
Recovery capacity	13 Gal (49 liters)
Working Grade	2%
Weight with batteries	370lbs (168 kg)
Weight without batteries	235 lbs (107 kg)
Dimensions (LxWxH)	48 x 26.0 x 38.0 (112.8 x 47.8 x 107.4 cm)
Drive Motor Power	1/5 HP (150W)

Table Of Contents

Safety Instructions	4
Unpacking Instructions	4
Inspection	4
Electrical	4
Batteries	4
Operator Responsibility	4
Machine Overview	5
Controls	6
Bail Handle	6
Handle Adjustment Knobs	6
Key Switch.....	6
Direction Switch.....	6
Squeegee Lift Lever	6
Battery / Fault Gauge	6
Speed Control.....	6
Charge Status Indicator.....	6
Optional Hour Meter	7
Optional Pump Kit.....	7
Vacuum Hose Routing.....	7
Circuit Breakers	7
Battery Compartment	8
Diagnostic Code Guide.....	8
Handle Adjustment	9
Angle Adjustment.....	9
Horizontal Adjustment.....	9
Solution Tank Drain Hose	10
Solution Level Indicator	10
Solution Fill Filter	10
Recovery Tank Drain Hose	11
Screened Float	11
Screened Float Removal.....	11
In-Line Solution Filter Assembly	12
Rear Squeegee	12
Cleaning the Squeegee	12
Changing the Squeegee Blades.....	12
Angle Adjustment	13
Height Adjustment	13
Brush Deck.....	14
Brush Loading / Unloading	14
Aquastop Solution Control.....	14
The Bulldog WD26	15
Machine Operation	16
To Turn ON Machine:.....	16
To Turn ON Vacuum:	16
To Turn ON Brush Motor:.....	16
To Turn on Cleaning Solution:	16
Direction Switch:.....	16
Speed control:	16
Driving:	16
To Charge Batteries:.....	16
Hour Meter (Optional):.....	16
After Use	16
Maintenance	17
Troubleshooting.....	18

Safety Instructions

IMPORTANT SAFETY INSTRUCTIONS

Operators must read and understand this manual before operating or maintaining this machine.

Do not operate this machine in flammable or explosive areas.

This machine is designed solely for scrubbing dirt and dust in an indoor environment. The manufacturer does not recommend using this machine in any other capacity.

The following information below may cause a potential hazard to the operator and equipment. Read this manual carefully and be aware when these conditions can exist. Take necessary steps to locate all safety devices on the machine and train the personnel operating the machine. Report any machine damage or faulty operation immediately. **Do not use machine if it is not in proper operating condition.**

FOR SAFETY DURING OPERATION

Keep hands and feet clear of moving parts while machine is in operation.

Make sure all safety devices are in place and operate properly. All covers, doors and latches must be closed and fastened before use. During operation, attention should be paid to other persons in the work area and especially if small children are present.

Electric motors and components can cause an explosion when operated near explosive materials or vapor. Do not operate this machine near flammable materials such as solvents, thinners, fuels, grain dust, etc.

Store or park this machine on a level surface only. To prevent unauthorized use, machine should be stored or parked with the key removed.

This machine is designed for level operation only. **Do not operate on ramps or inclines greater than 2%.**

This machine is not suitable for picking up hazardous dusts.

Use caution when moving this machine into areas that are below freezing temperatures. Any water in the tanks or hoses can cause damage to the machine.

FOR SAFETY WHEN SERVICING or MAINTAINING MACHINE

Stop on level surface.

Disconnect the power to the machine by unplugging the red Battery connector located under the recovery tank near the batteries.

Avoid moving parts. Do not wear loose jackets, shirts, or sleeves when working on machine.

Avoid contact with battery acid. Battery acid can cause burns. When working on or around batteries, wear protective clothing and safety glasses. Remove metal jewelry. Do not lay tools or metal objects on top of batteries.

Charging batteries generates explosive gasses.

Do not charge batteries when open flames or sparks are present. Do not smoke.

Make sure the charger is turned off before disconnecting it from the machine.

Charge the batteries in a well-ventilated area with the battery cover removed completely.

Do not clean machine with a pressure washer.

Authorized personnel must perform repairs and maintenance. Use Minuteman supplied replacement parts.

SAVE THESE INSTRUCTIONS

Inspection

Carefully unpack and inspect your **Bulldog WD26 Walk-Behind Scrubber** for shipping damage. Follow unpacking instructions on shipping pallet. Each unit has been tested and thoroughly inspected before shipment. Any damage is the responsibility of the delivery carrier who should be notified immediately.

Electrical

This machine is battery operated and designed to operate on 24 volts DC (2) 12-volt batteries.

Batteries

The recommended batteries are rated 140Ah WET (Manufacturer P/N 956140) or 95Ah Maintenance Free GEL (Manufacturer P/N 956100). We do not recommend mixing AMP hour capacities. Alternate battery sets can be used if they equal physical size and capacity. If alternate battery sets are used please contact the manufacturer for on board charger settings.

Operator Responsibility

Read this manual carefully before operating this machine.

The operator is responsible for taking care of the daily maintenance and check ups of the machine to keep it in good working condition. The operator must inform the service mechanic or supervisor when the scheduled maintenance intervals are required as stated in the *MAINTENANCE* section of this manual.

Before starting familiarize yourself with the machine and its controls (see "Machine Overview, Front", "Machine Overview, Rear", "Control Console" diagrams).

Machine Overview

Machine Overview - Front

- A CUP HOLDER
- B SOLUTION FILL PORT
- C RECOVERY TANK LID
- D RECOVERY TANK
- E BRUSH DECK
- F FRONT WHEEL (see note)
- G REAR CASTER
- H SOLUTION TANK

* NOTE - Front tires are foam filled to be maintenance-free. No air can be added.

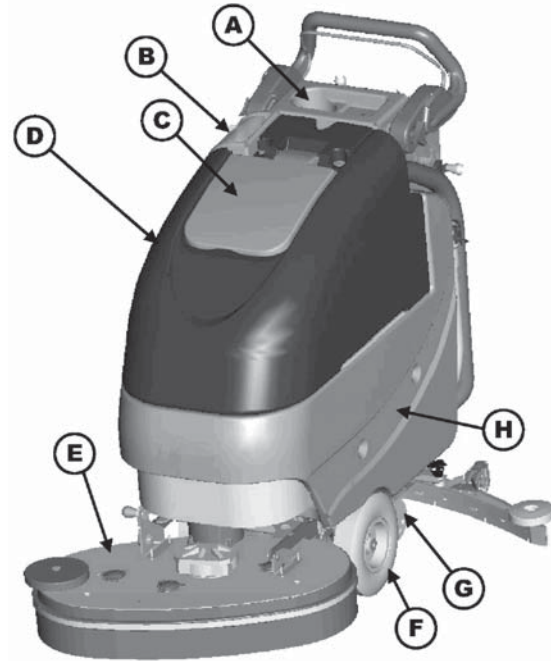

Machine Overview - Rear

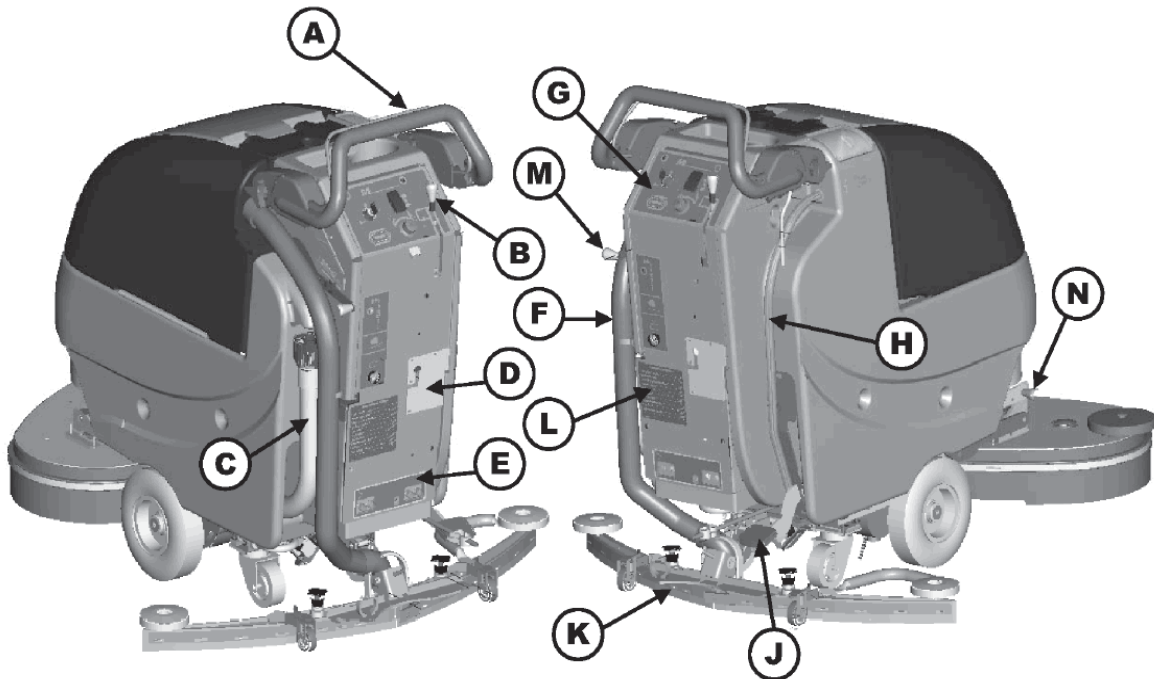

- | | | |
|----------------------------|------------------------------|--------------------------|
| A BAIL HANDLE | F RECOVERY HOSE | K REAR SQUEEGEE |
| B SQUEEGEE LIFT LEVER | G CONTROL PANEL | L DIAGNOSTIC CODE GUIDE |
| C RECOVERY TANK DRAIN HOSE | H SOLUTION TANK DRAIN HOSE / | M SOLUTION CONTROL LEVER |
| D ONBOARD CHARGER CORD | LEVEL INDICATOR | N DECK TILT HANDLE |
| E CIRCUIT BREAKERS | J BRUSH DECK LIFT PEDAL | |

Machine Overview

Controls

- A BAIL HANDLE
- B HANDLE ADJUSTMENT KNOB
- C KEY SWITCH
- D DIRECTION SWITCH
- E SQUEEGEE LIFT LEVER
- F BATTERY / FAULT GAUGE
- G SPEED CONTROL
- H CHARGE STATUS INDICATOR
- J SOLUTION CONTROL LEVER
- K AQUASTOP SOLUTION SETTING

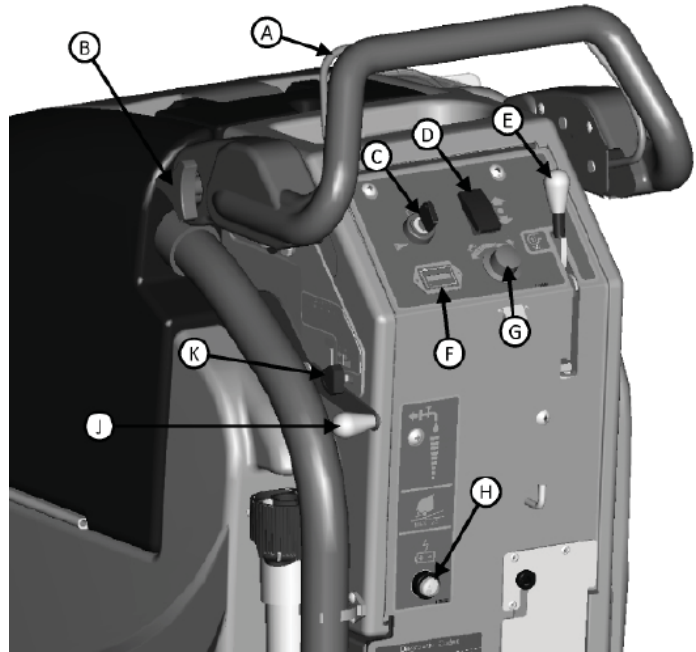

Bail Handle

(A) When the scrub deck is lowered to the floor, the bail handle enables the brush motor and moves the machine forward once depressed.

Handle Adjustment Knobs

(B) Allows the handle position to be raised or lowered.

Key Switch

(C) Controls the machine's power (Off/On) with a key for safety. When it is turned to the on position, the machine will operate (after 5 second diagnostic check, see battery gauge).

Direction Switch

(D) This 3 position switch sets the direction the machine will move when the bail handle is pulled. The middle position is neutral - brushes & vacuum will operate but machine will not move.

Squeegee Lift Lever

(E) When moved to the top position, the squeegee is lowered and the vacuum motor is turned on. When locked in the bottom position, the squeegee is raised and the vacuum motor shuts off (after a 10 second delay).

Battery / Fault Gauge

(F) This gauge displays the remaining battery charge. This gauge also displays any fault codes that might occur with the Drive Motor Controller (see Diagnostic Codes). Gauge will blink for 5 seconds when key is first turned on, to run diagnostic check before machine can be used.

Speed Control

(G) This control sets the speed at which the machine will move.

Charge Status Indicator

(H) This gauge displays the status of the batteries during charging. The gauge has a readout of 3 LEDs. 1 Green, 1 Yellow, 1 Red. Green indicating a full charge, Yellow indicating 80% charged, Red indicating the batteries are charging.

Solution Control Lever

(J) This lever controls the rate at which solution is dispensed. Moving the lever up will increase the amount of solution. Moving the lever down will decrease the amount. Moving the lever all the way down shuts off solution flow.

Aquastop Solution Setting

(K) This bracket is a guide to limit the amount of solution dispensed for consistent performance.

Machine Overview

Optional Hour Meter

The Manufacturer offers an optional hour meter for the Floor Scrubber. The optional kit replaces the power cord mounting bracket at the rear of the machine with one that contains an hour meter.

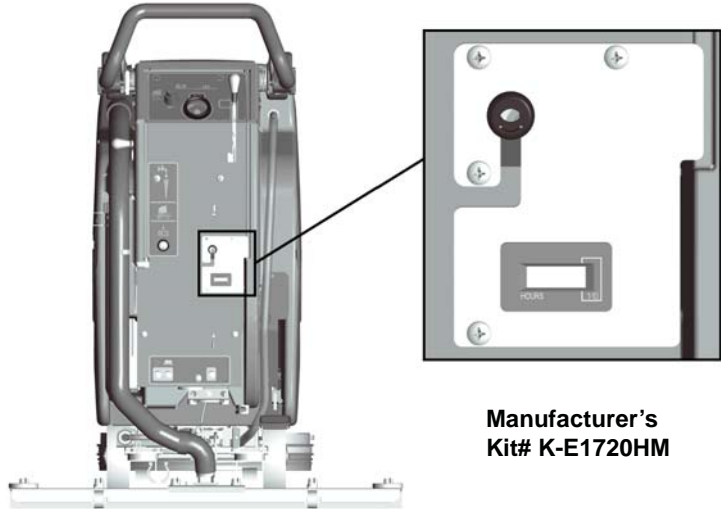

Optional Pump Kit

The Manufacturer offers an optional pump kit for the floor scrubber. The pump will turn on when the switch is toggled to the **ON** position. The hose to coupler fills, then the pump shuts off until the wand (not supplied) is connected and chemical is dispensed.



Vacuum Hose Routing

For best results, route the vacuum hose as shown below:

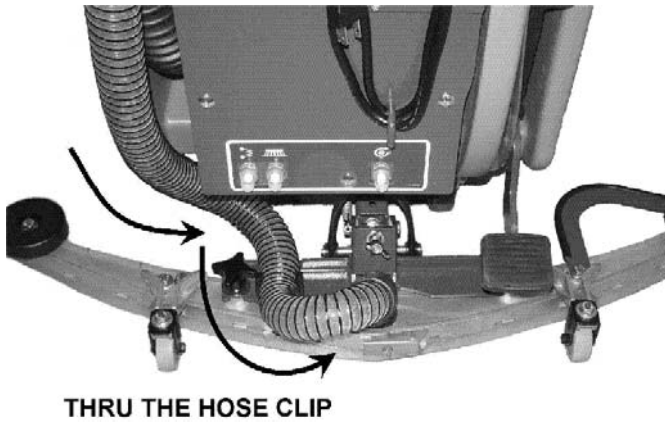

Circuit Breakers

The circuit breakers are located at the bottom of the back panel of the machine.

- A Main Control Circuit Breaker - 4A**
- B Brush Motor Circuit Breaker - 30A**
- C Vacuum Motor Circuit Breaker - 20A**
- D Drive Motor Circuit Breaker - 20A**

If any of the functions above are not operating, check if the circuit breaker buttons have tripped. Press to reset.

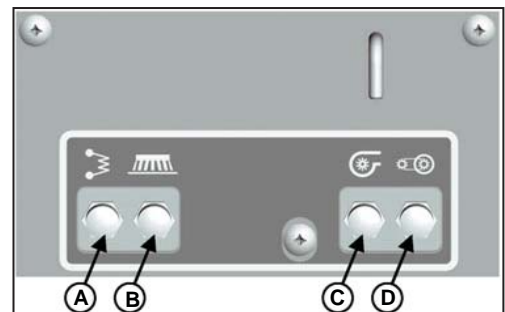

Machine Overview

Battery Compartment

The battery compartment is located under the recovery tank. The Battery compartment can be accessed for servicing and maintenance by tilting the recovery tank (make sure recovery tank has been drained before tilting). The battery compartment contains two 12-volt batteries connected in series. Connect the batteries according to the battery connection diagram (see *diagram*). The recommended batteries are 140Ah (manufacturer's P/N 956140) or 95Ah (manufacturer's P/N 956100) Gel. The battery tray may be drained if necessary using the orange drain hose located above the rear caster on the right side of the machine.

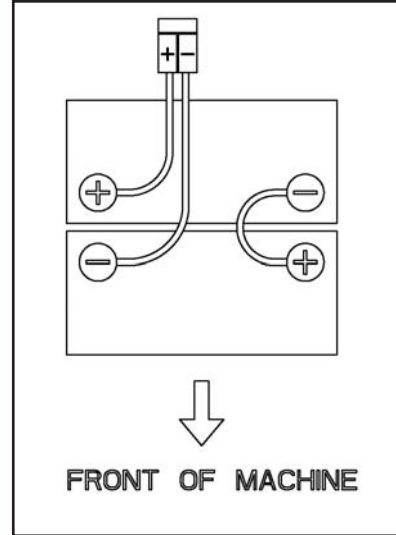

Diagnostic Code Guide

When an error or fault occurs within the machine, a fault code will appear on the battery gauge represented by a specified number of flashing LEDs. (See "Troubleshooting" for further information)

Diagnostic Codes

The number of flashing bars on the battery gauge represent fault codes as indicated below:

Low Battery Voltage <i>Check condition of battery and connections</i>	1
Drive Motor Fault <i>Check all connections between the motor and controller</i>	2
Drive Motor Short Circuit <i>Motor has a short circuit to a battery connection. Contact Service Agent</i>	3
Battery Lockout <i>Battery voltage is too low, controller is preventing function. Charge Batteries</i>	4
Not Used	5
Drive Inhibit <i>Check battery charger, drive is inhibited when plugged in</i>	6
Throttle fault <i>Restart keyswitch-ball handle was activated prior to turning machine on</i>	7
Drive Controller Fault <i>Check all connections are secure</i>	8
Not Used	9
High battery voltage <i>Check condition of battery and connections</i>	10

Machine Overview

Handle Adjustment

The WD26 handle was designed with operator comfort in mind. The angle and horizontal position of the handle can be adjusted to suit the needs of the operator.

Angle Adjustment

The handle angle can be adjusted without tools by loosening the **Angle Adjustment Knob (A)** on each side and rotating the handle to the desired position. There are 5 angular positions 11.25° apart for a total of 45° between the minimum and maximum position.

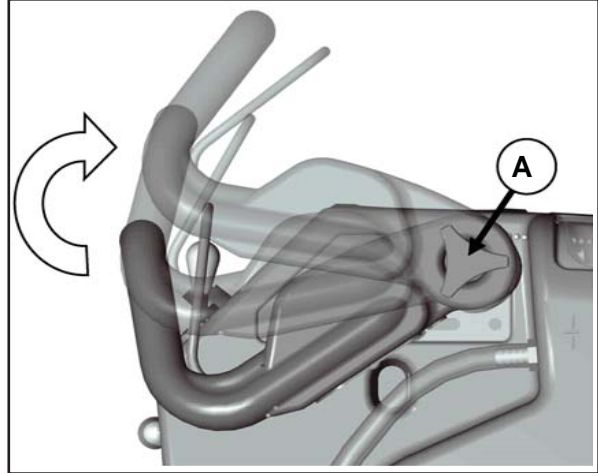

Horizontal Adjustment

The horizontal position can be adjusted by removing the 4 **Mounting Bolts (B)** (2 each side) with a 9/16" socket and sliding the **Mounting Plate (P)** to one of the 3 available positions. The machine is shipped from the factory in position 1.

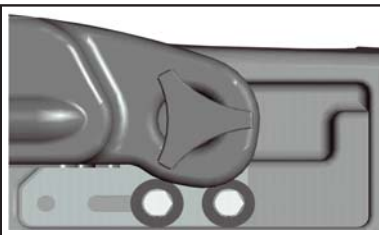
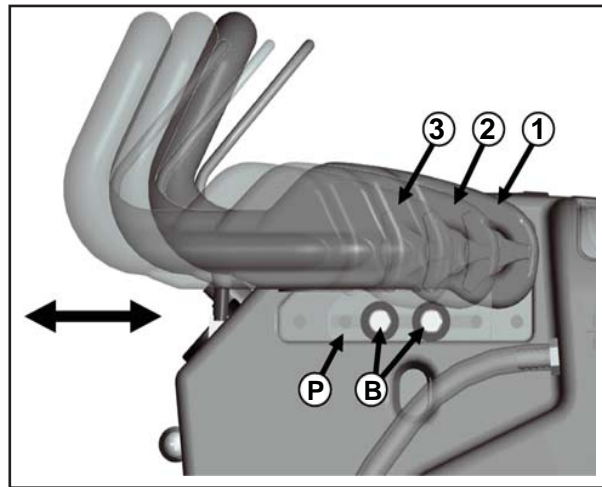

**Plate Position 3
(Fully Extended)**

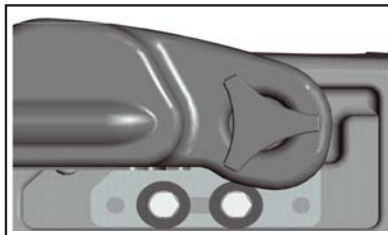
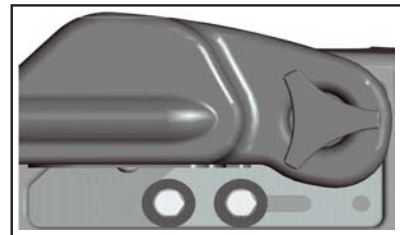

Plate Position 2

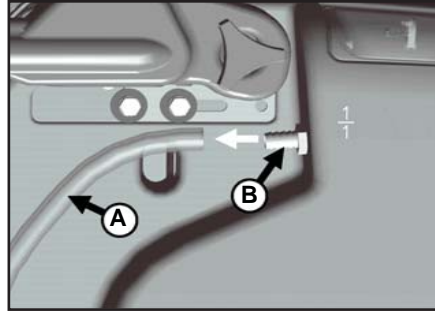

**Plate Position 1
(Shipping Position)**

Machine Overview

Solution Tank Drain Hose

The solution tank may be drained by removing the **Solution Tank Drain Hose (A)** from the **Hose Barb (B)** and routing the hose to a floor drain.



Solution Level Indicator

The Solution Tank Drain Hose also serves as a water level indicator for the solution tank. The amount of water remaining in the solution tank can be seen through the clear drain hose. Level markers molded into the solution tank are positioned at 1/4, 1/2, 3/4, and full levels.

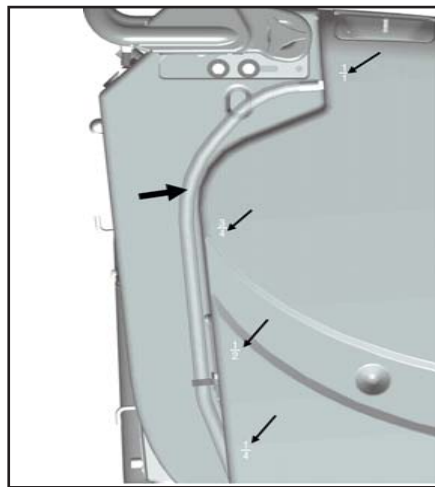

Solution Fill Filter

The **Solution Fill Filter (B)** should be cleaned regularly. To remove, simply open the **Solution Tank Lid (A)** and pull the filter out.

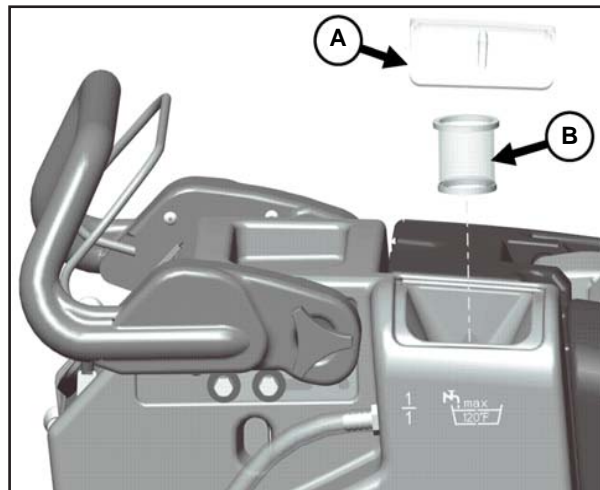

Machine Overview

Recovery Tank Drain Hose

Twist Cap to Open and Drain



Twist & Lift cap to clean out debris



Note: Debris left on the o-ring will cause a vacuum leak.

Screened Float

If the recovery tank (C) is overfilled or a large amount of foaming is present, the screened float (B) blocks the vacuum intake inside the tank protecting the vacuum motor and internal electronics from water damage. It is essential to keep the float in working order through regular maintenance.

The float should be cleaned daily by thoroughly rinsing with a hose. Removal of the screened float is not necessary for daily maintenance.

At least once a month the screened float should be completely removed, cleaned, and checked for any damage to the seal or metal screen.

WARNING: Damage to the machine may occur if operated without the screened float properly in place.

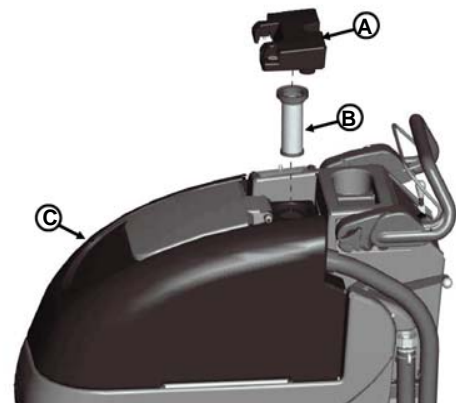

Screened Float Removal

The screened float is positioned between the vacuum manifold (A) and recovery tank (C). The screened float (B) can be accessed by removing the 1.5" bolt (D) and two 1.25" bolts (E) that attach the manifold to the recovery tank using a 7/16" socket.

- A Vacuum Manifold
- B Screened Float
- C Recovery Tank
- D 1.5" Bolt
- E 1.25" Bolt (2)
- F Helical Washer (3)
- G Flat Washer (3)



Machine Overview

In-Line Solution Filter Assembly

The solution solenoid, which shuts off solution flow when the bail handle is released, is protected from debris by the in-line filter assembly. The filter assembly is located at the rear of the machine on the left hand side, just under the solution tank. It is important to check and clean the screened washer inside the assembly regularly to ensure proper solution flow. To open, unscrew the assembly (Note that the cone of the washer is facing out toward the rear of the machine). Remove washer and rinse, reinsert and screw assembly together, tightening by hand. **Overtightening with tools may damage the plastic threads.**

- A Fitting, MGHT
- B Screened Washer
- C Hose Barb Insert
- D Fitting, FGHT

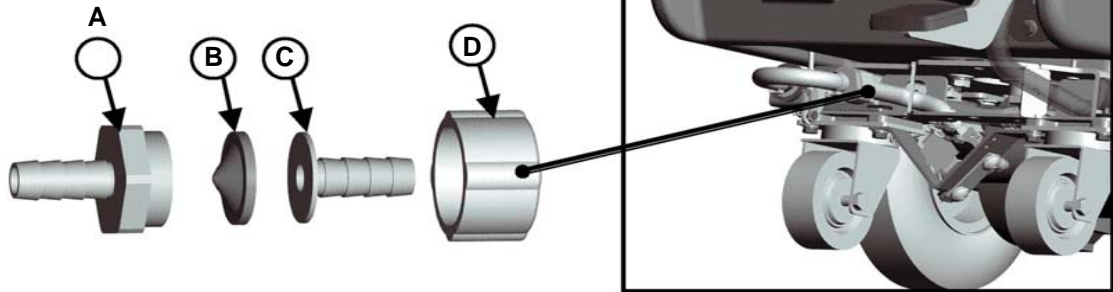

Rear Squeegee

- A Squeegee
- B Star-shaped knob
- C Adjusting screw for angle adjustment
- D Suction hose
- E Blade fastening latch
- F Washers for caster height adjustment
- G Caster Wheel Axle

Cleaning the Squeegee

Check the squeegee (A) daily and clean as necessary.

1. Pull off the suction hose (D).
2. Loosen the two star-shaped knobs (B).
3. Remove the squeegee (A).

Changing the Squeegee Blades

Check the inner and outer squeegee blades on the squeegee (A) weekly for signs of wear. The squeegee blades can be reused by turning them (can be turned for 4 total uses).

1. Pull off the suction hose (D), loosen the two star-shaped knobs (B) and remove the squeegee.
2. Unlock the fastening device (E) and remove the outer squeegee blade. Turn the squeegee blade or install a new one, as necessary. Change the inner squeegee blade in the same way.

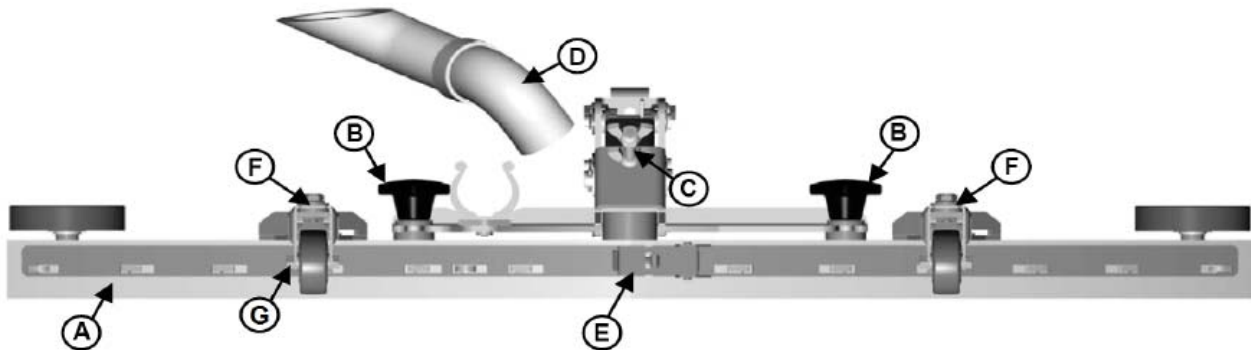

Machine Overview

Squeegee Blades Angle Adjustment

The angle adjustment is the decisive factor in ensuring that the squeegee blades on the squeegee lie evenly on the floor.

1. Park the machine on a level surface and lower the squeegee.
2. Loosen the lower wing nut **(B)** on the adjusting screw **(A)** and adjust the squeegee using the adjusting screw so that the ends of the squeegee blades still have contact with the floor. By turning the adjusting screw **(A)** counterclockwise, the clearance between squeegee blade and floor is **increased** in the center (Fig. 1). When turning the adjusting screw **(A)** clockwise, the clearance between squeegee blade and floor is **reduced** in the center (Fig. 2).
3. Switch the machine on and check the suction pattern. When the machine is in operation, the entire surface of the squeegee blades (center and outer areas) must be applied as evenly as possible.
4. Tighten the lower wing nut **(B)** on the adjusting screw **(A)** against the metal bracket to lock in the pitch setting.

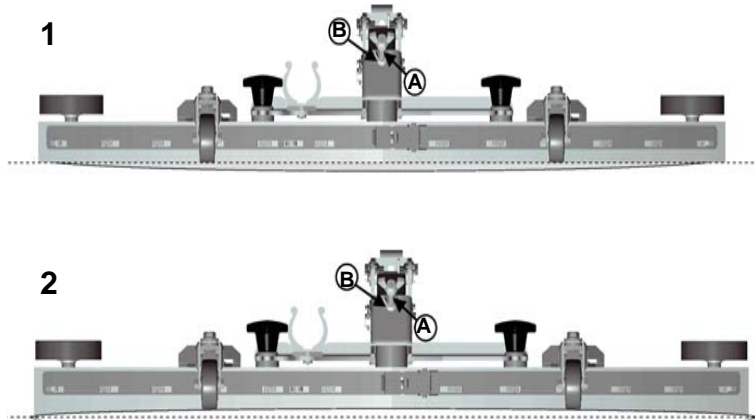

Squeegee Blades Height Adjustment

If streaks are present, despite an optimum angle adjustment, the clearance between the caster wheels and floor must be adjusted by changing the number of washers underneath the bracket that holds the wheel. The squeegee height is preset at the factory to 3mm.

In cases of very smooth floors, e.g. finished floors, PVC, linoleum, etc., see 2mm illustration for washer configuration.

In cases of very uneven floors, e.g. poorly laid tiles (water does not run off) ,, configure as shown in 4mm illustration.

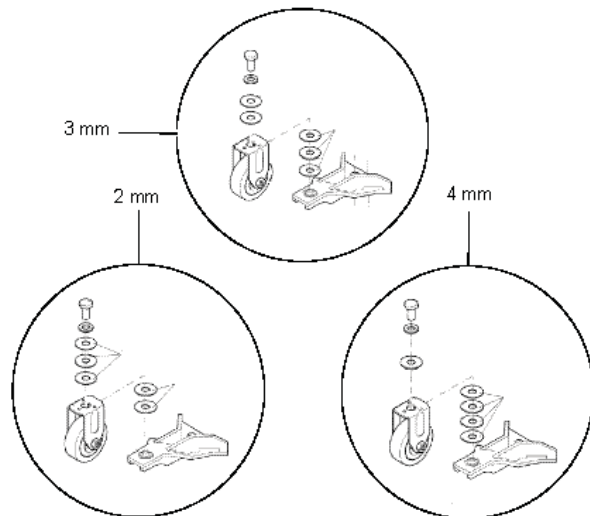

Keep the extra washers by installing them above the bracket as shown.

Machine Overview

Brush Deck

Brush Loading / Unloading

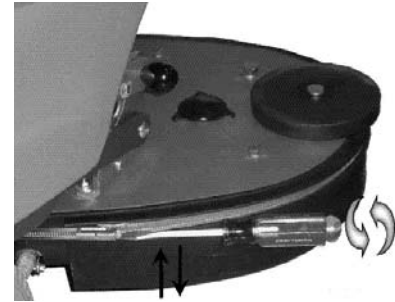
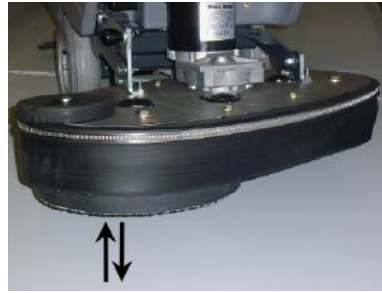
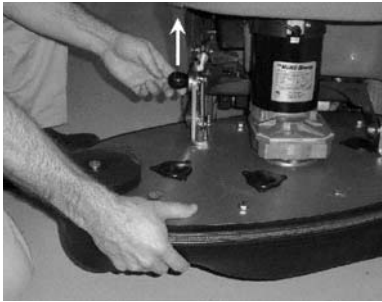

1. Brush Deck may be tilted up for easier brush installation/removal & to clear steep ramps. Lift the handle on the upper lever which connects the brush deck to the machine, tilt the deck up, release the handle & the lever will lock into place. Lift the handle again to move the deck back to horizontal.
2. Brushes are installed/removed by hand. Push each brush up onto the hub until it "clicks". To remove, pull down on the edge of each brush.
3. The splash guard may be moved up or down as the brush/pad wears by loosening the clamp on the back side of the deck with a flat-head screwdriver or 9/32" (7mm) socket, then slide the splash guard to the desired height & retighten the clamp.

Aquastop Solution Control

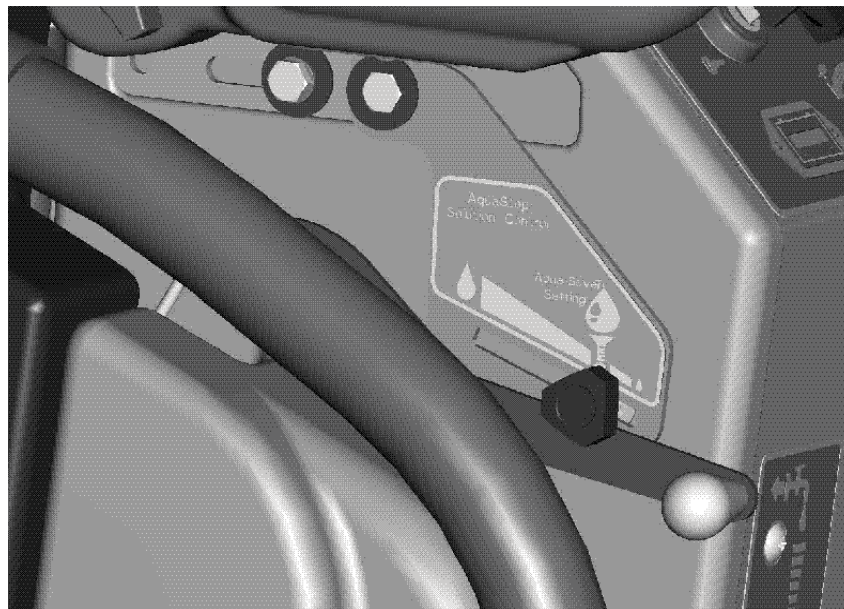

In order to consistently conserve water when using Aquastop brushes, the guide will stop the solution control lever at a low rate setting. This setting may be adjusted by loosening the knob, adjusting the lever, and retightening the knob. Slide the knob all the way forward to dispense maximum solution.

The Bulldog WD26

This machine was designed with total operator comfort and ease of use in mind. All machine components have been designed as a total system to efficiently clean dirty floors. *Please contact your representative for specific recommendations for the correct brush type and chemical applications.*

Before using the machine, always perform the following steps to ensure proper machine operation:

- Check under the machine for leaks.
- Check the rear squeegee for wear and damage.
- Check the solution and recovery tank levels.

After using the machine, always perform the following steps:

- Check the battery charge level. Charge batteries if necessary. When charging batteries, extra precaution is required:
 - Battery acid can cause burns.
 - When working on or around batteries, always wear protective clothing and safety glasses.
 - Remove metal jewelry. Do not lay tools or metal objects on top of the batteries.
 - Charging batteries generate explosive gasses.
- **DO NOT CHARGE BATTERIES WHEN OPEN FLAMES OR SPARKS ARE PRESENT. DO NOT SMOKE.**
 - Charge the batteries in a well-ventilated area.
 - Fluid levels should be checked before and after charging and maintained at the proper levels. If low, add distilled water until the metal plates are covered.
 - If the machine is not used for an extended period of time, batteries should be kept fully charged with a boost charge once a week.
- Check for wire, string, or twine wrapped around the scrub brushes.
- Check the rear squeegee for wear and damage.
- Check the rear squeegee suction hose for obstructions.
- Drain and rinse the recovery tank.
- Check under the machine for leaks.
- Check the service records to determine maintenance requirements.

WARNING!

- **Be sure you understand the machine controls and their functions.**
- **While on ramps or inclines, avoid sudden stops when tanks are filled.**
- **Avoid abrupt sharp turns. Slow down driving speed when going downhill.**

Machine Operation

To Turn ON Machine:

Turn key to operate position (I). Wait for battery gauge to stop flashing, approximately 5 seconds. (If flashing continues, see troubleshooting guide)

To Turn ON Vacuum:

Lower squeegee into operating position, vacuum motor will turn ON automatically.

To Turn ON Brush Motor:

Lower the scrub deck to the floor by moving the brush lift pedal from the "home" (down) position to the operating position (up). Depress the operator bail handle. Brush motor will turn ON.

To Turn on Cleaning Solution:

Move solution lever from closed (down) position up to the desired flow position. With the scrub deck on the floor, depress the bail handle, solution will begin to flow.

Note: An electronic solution solenoid valve will stop solution flow whenever the bail handle is released.

Direction Switch:

Select direction of machine by moving the directional rocker switch from the neutral position to the forward or reverse position. The direction of the machine movement is shown on the operator panel with forward and reverse arrows.

Speed control:

Move the speed dial to the desired position. Turning the dial clockwise increases the speed. Turning the dial counterclockwise decreases the speed.

Driving:

Depress the operator bail handle, the machine will move in the direction selected.

To Charge Batteries:

When the battery / fault gauge reaches the red zone the batteries need to be recharged. Take the machine to a well ventilated area, unwind the battery charger power cord from the electrical box cover and plug into an appropriate power source. After approximately 10 seconds the battery charge status indicator will turn on. Check the battery water levels before each use, refill as needed with distilled water. **Caution: do not overfill. Fill water 1/4 " - 1/2" above the separators. Failure to maintain the batteries may result in battery failures.**

WARNING: Charging batteries generates explosive gasses. Do not charge batteries when open flames or sparks are present. Do not smoke. Charge the batteries in a well-ventilated area .

Hour Meter (Optional):

Hour meter will automatically record operating time of the brush motor.

After Use

1. When finished scrubbing, lift the scrub deck. Lift the rear squeegee (the vacuum motor will turn off after 10 seconds). Move the machine to a service area for daily maintenance and review items that may need service.
2. Empty the solution tank by disconnecting the **solution tank drain hose** from the barb fitting and routing hose to a drain. Rinse the tank with clean water to prevent any buildup of dried chemicals that could clog the plumbing.
3. Empty and clean the recovery tank by flushing with a hose. Be sure to also clean the float shut off screen.
4. Remove the **brushes** or pad holders and rinse them in warm water and hang to dry.
5. Remove the **rear squeegee and recovery hose**, rinse with warm water and reinstall after cleaning (see page 13 for correct hose installation).
6. Check the **maintenance schedule** in the next section and perform any required maintenance before storing the machine.
7. Store the machine indoors in a clean dry place. Keep from freezing. Leave solution and recovery tank lids open for ventilation to prevent odor buildup.
8. Turn **Key switch OFF (O)** and remove key.

Maintenance

Daily	Weekly	Monthly	Yearly
Charge Batteries	Inspect Brush Deck Splash Guard for Debris	Lubrication - Grease Fittings	Check Carbon Brushes
Check/Clean Tanks and Hoses	Inspect and Clean In-Line Solution Filter		
Check/Clean/Rotate the Brushes	Rinse off the underside of Brush Deck		
Check/Clean the Squeegee	Check each Battery Cell (s) Water Level		
Check/Clean Vacuum Shut-Off Float in Recovery Tank			

Have a qualified service technician check the vacuum motor carbon motor brushes once a year or after 300 operating hours. The brush motor and transaxle motor carbon brushes should be checked every 500 hours or once a year.

NOTE: Refer to the Service Manual for more detail on maintenance and service repairs.

Regularly scheduled lubrication of certain machine parts should be performed to insure trouble-free operation of the machine. *Apply a generous amount of grease into the fittings on the machine until grease seeps out around the bearings.*

The grease points are listed below:

- *Rear caster swivel (2)*

Apply lubricant or light machine oil to lubricate the:

- *Pivot mounting point of the squeegee lift mechanism to the chassis (1)*
- *Rear squeegee caster wheel axle (2)*

Troubleshooting

Problem	Possible Cause	Remedy
Poor water pick up	Worn or torn squeegee blades	Rotate or replace blades
	Recovery tank full	Empty recovery tank
	Recovery tank drain hose leak	Clean and secure drain hose cap or replace
	Recovery tank lid gasket leak	Replace gasket lid cover properly
	Debris caught in squeegee	Clean squeegee
	Vacuum hose clogged	Remove debris and flush hose
	Recovery hose to squeegee or recovery tank disconnected/damaged	Reconnect or replace recovery hose
Poor scrubbing performance	Worn brush or pad	Replace brush or pad
	Wrong brush or cleaning chemical	Consult manufacturer
	Debris caught on scrub brush	Remove debris
	Moving machine too fast	Slow down for more complete scrubbing
	Not using enough solution	Adjust solution flow setting
	Low battery charge	Recharge batteries
Inadequate solution flow or no solution to the floor	Solution tank empty	Fill solution tank
	Solution lines, filter , or valves clogged	Flush lines and clean solution filter
	Solution Lever in down position	Raise lever up
Machine does not move	Squeegee is down and directional switch is in reverse position	Raise squeegee when in reverse mode
	Traction drive circuit breaker has tripped	Reset circuit breaker
	Batteries lost power	Recharge batteries
	Directional switch in neutral position	Activate FWD or REV position
Machine does not operate	Tripped control power circuit breaker	Reset breaker
	Batteries have low charge	Recharge batteries
	Battery charger operating	Unplug battery charger when charge is complete
	Key switch off	Turn key on
	Bail handle depressed too quickly after turning key on	Turn key off, turn on, wait until battery gauge lights up without flashing
Vacuum motor does not turn on	Recovery tank full	Empty recovery tank
	Excessive foam in recovery tank	Empty recovery tank, rinse off the screened float, inside recovery tank Use less or change chemical Use defoaming agent
	Carbon brushes worn	Replace carbon brushes
	Tripped vacuum motor circuit breaker	Reset breaker
	Broken vacuum limit switch	Replace switch by squeegee lift lever
	Squeegee in raised position	Lower squeegee
Batteries do not charge	Charger not plugged to wall outlet	Plug into wall outlet
	Circuit breaker tripped in wall outlet	Reset breaker
	Battery disconnected from machine	Connect battery to machine
	Charger malfunction	Call service
Brush does not unload	Foot pedal not in the "home" position	Place pedal in notch
	Tripped brush motor circuit breaker	Reset breaker
	Broken brush motor switch	Replace switch
	Damaged brush block or drive hub	Replace

Troubleshooting

Charger Warning Indicators		
	LED status	Description
Warning	RED LED lamp blinks once	Output open circuit or short circuit or reverse polarity connection of charger to battery. Battery voltage is too high (may be connected to wrong voltage battery).
	RED LED lamp blinks twice	Abnormal cycle (may be weak or bad battery). Charging time has safety timed out due to battery problem.

Fault / Diagnostic Codes

The Battery / Fault gauge will flash when a fault is detected. A decal labeled "Diagnostic Codes" is located below the battery gauge as an abbreviated and convenient guide to determine the cause of the fault and the remedy (refer to machine or see "Diagnostic Code Guide" section of this manual). The flashing codes are for the following:



The battery needs charging, there is a bad connection to the battery or dependent on programming, may indicate that the battery lockout function is active and the controller is in a restricted mode of operation. Check the connections to the battery. If the connections are good, try charging the battery.



The bail handle was activated prior to turning the machine on. Make sure that the bail handle is in the rest position. Restart the key switch.



There is a bad connection to the motor. Check all connections between the motor and the controller.



A controller fault is indicated. Make sure that all connections are secure.



The motor has a short circuit to a battery connection. Contact your service agent.



Not used.



The battery charge level has fallen below the Battery Lockout level and the controller is inhibiting certain machine functions. Charge the battery.



An excessive voltage has been applied to the controller. This is usually caused by a poor battery connection. Check the battery connections.



Not used.



The controller is being inhibited from driving, this may be because the battery charger is connected.



www.bulldogscrubbers.com
877-292-3935